



Rüstzustand: Turm Nadelausleger

Tragkraft kg  
abgestützt, 360° drehbar  
Sicherheit 62,5%=1,6

Ausladung m	mit Ballast				ohne Ballast			
	Ausleger		Ausleger		Ausleger		Ausleger	
	13,5m	18,0m	22,5m	13,5m	18,0m	22,5m	13,5m	18,0m
5	15 000			15 000				
5,5	15 000			15 000				
6	15 000	12 000		14 000	12 000			
6,5	15 000	12 000		12 400	12 000			
7	14 200	12 000	10 000	11 100	11 400	10 000		
7,5	13 000	12 000	10 000	10 100	10 400	10 000		
8	12 000	12 000	10 000	9 300	9 500	9 400		
8,5	11 200	11 100	10 000	8 600	8 700	8 700		
9	10 400	10 400	10 000	8 000	8 000	8 100		
9,5	9 800	9 700	10 000	7 500	7 400	7 400		
10	9 300	9 100	9 300	7 100	6 900	6 900		
11	8 400	8 100	8 100	6 300	6 000	6 000		
12	7 600	7 300	7 100	5 700	5 300	5 200		
13	7 300	6 600	6 300	5 200	4 800	4 600		
14	6 600	6 100	5 700	4 700	4 300	4 200		
15		5 700	5 200		4 000	3 800		
16		5 300	4 800		3 700	3 500		
17		5 000	4 500		3 500	3 300		
18		4 700	4 200		3 200	3 000		
19			3 900			2 800		
20			3 700			2 600		
21			3 500			2 400		
22			3 300			2 200		
23			3 100			2 100		

Rüstzustand: Schwerlast

Tragkraft kg  
abgestützt mit Ballast, 360° drehbar  
Sicherheit 77% (1,3)

Ausladung m	ohne Nadelausleger		mit aufliegendem Nadelausleger	
	Turmlänge		Turmlänge	
	14,3m	18,3m	14,3m	18,3m
3	45 000	30 000	45 000	30 000
3,5	45 000	30 000	45 000	30 000
4	45 000	30 000	40 000	30 000
4,5	45 000	30 000	31 000	30 000
5	34 000	30 000	25 000	24 600
5,5	28 000	27 000	21 000	20 000
6	24 000	22 000	17 800	16 800
6,5	20 200	19 000	15 200	14 400
7	18 000	17 000	13 000	12 400
7,5	15 600	15 000	11 400	10 800
8	13 600	13 400	10 000	9 500
8,5	12 000	12 000	8 800	8 400
9	10 800	10 800	7 800	7 400
9,5	9 800	9 600	7 000	6 500
10	9 000	8 800	6 400	6 000
11	7 800	7 200	5 800	5 000
12	7 000	6 200	5 200	4 200
13	6 500	5 400	4 800	3 600
14		4 800		3 100
15		4 200		2 700
16		3 600		2 300
17		3 200		2 000

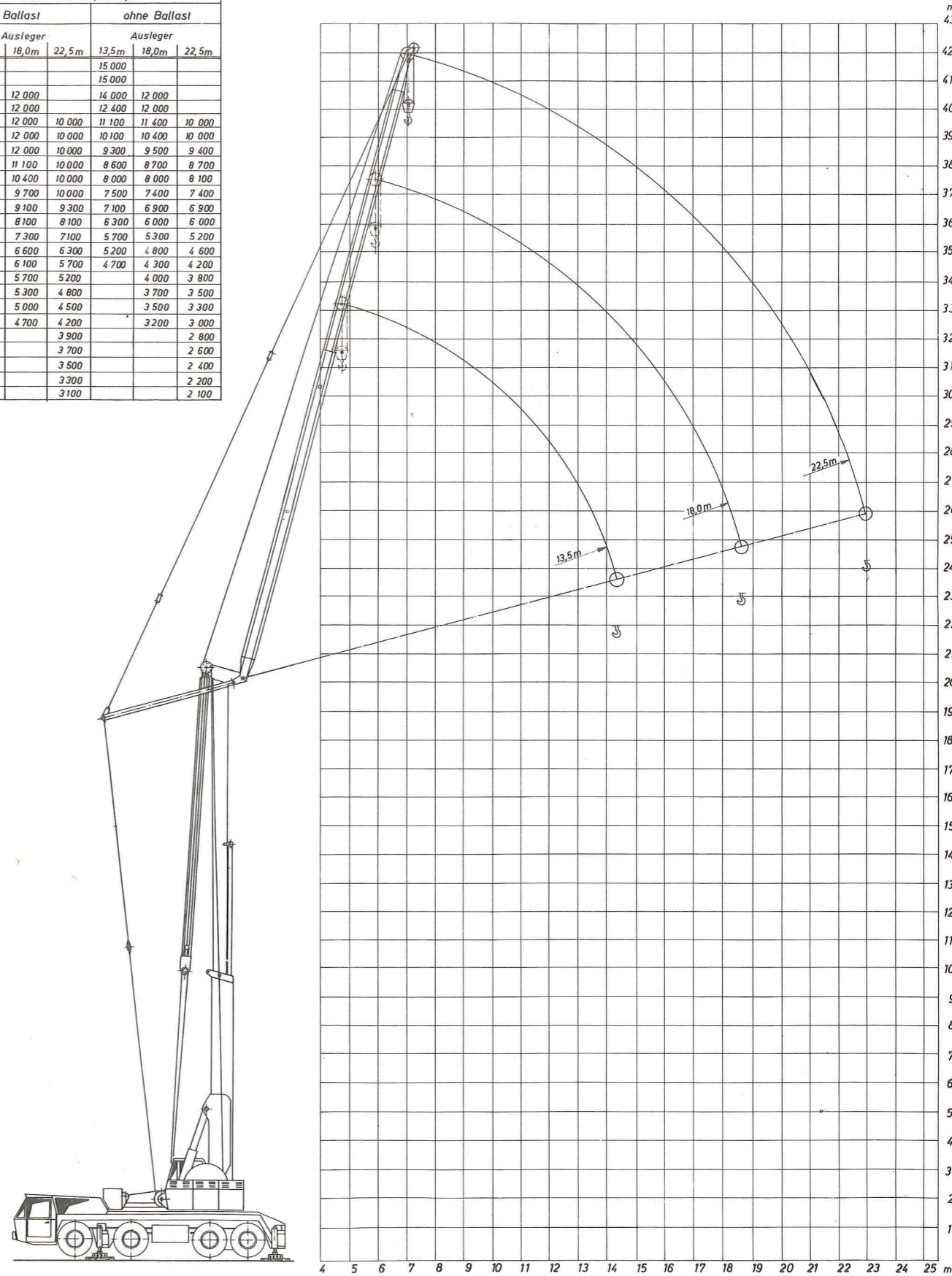
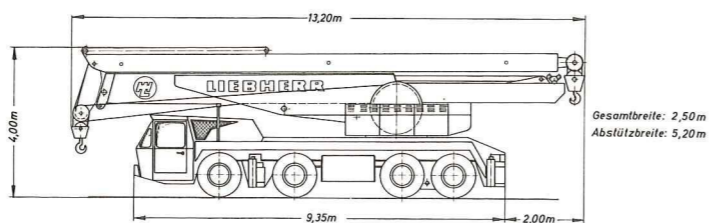
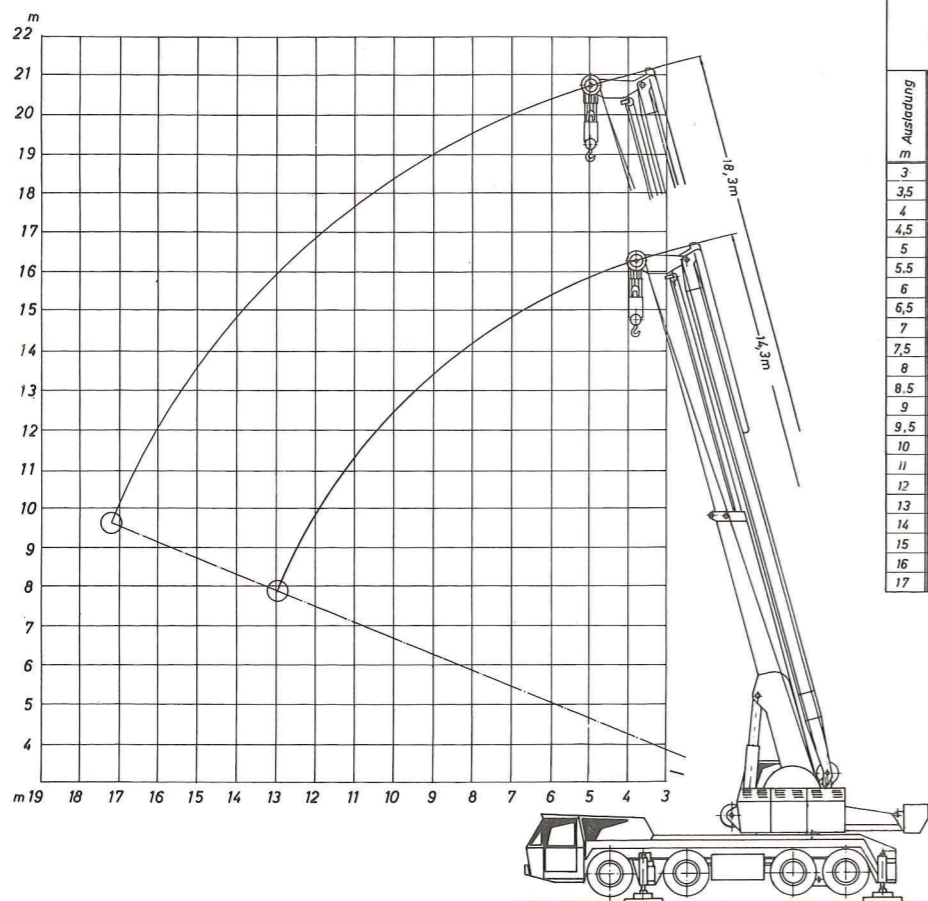

Projektblatt  
Nr:  
A1/410P-0003

Massblatt  
Form Auk 80T

**LIEBHERR**  
AUTOKRAN

Tabelle mit technischen Daten  
zum Liebherr Autokran Form Auk 80T